



# **Glasswasher, Undercounter, Hood Type, Rack Type, Flight Type Dishwashers**





## Our brand

### **Veetsan - The Dishwashing Professional.**

A reliable choice and good deal wherever professional dishwashing is requested all over the world.

## Our brand promise

“Quality & Value” is what Veetsan stands for and has proven in the market. Being part of Electrolux Professional Group, a global leader in commercial appliances, Veetsan – the dishwashing professional supports businesses to becoming more profitable, reliable and trustworthy.

## Product range

- Glasswasher
- Undercounter
- Hood type
- Rack type
- Flight type

**200+**  
employees

**10,000+**  
dishwashing sets  
/ year

## Customers

- Hotel
- Restaurant chains
- Large food and beverage businesses
- Institutions

**20+**  
sales and  
service offices  
across China

# Our range

## Undercounter Glasswashers

- Max capacity: 30 racks/hour
- External dimension: 455×550×700mm
- Basket dimension: 400×400mm
- Voltage: 220V/50Hz/1N
- Water consumption: 2L/rack
- Clearance height: 290mm



## Undercounter Dishwashers

- Max capacity: 40 racks/hour
- External dimension: 600×600×840mm
- Basket dimension: 500×500mm
- Voltage: 380V/50Hz/3N  
220V/50Hz/1N
- Water consumption: 2.8L/rack
- Clearance height: 310mm



## Hood Type Dishwashers VHT60

- Max capacity: 60 racks/hour
- External dimension: 746×755×1512mm
- Basket dimension: 500×500mm
- Voltage: 380V/50Hz/3N
- Water consumption: 2.5L/rack
- Clearance height: 440mm



## Hood Type Dishwashers VHT65

- Max capacity: 65 racks/hour
- External dimension: 752×755×1549mm
- Basket dimension: 500×500mm
- Voltage: 380V/50Hz/3N
- Water consumption: 2.3L/rack
- Clearance height: 440mm



## Rack Type Dishwashers

- Max capacity: 200 racks/hour
- External dimension: 1148×706×1840mm  
1748×706×1713mm
- Basket dimension: 500×500mm
- Voltage: 380V/50Hz/3N
- Water consumption: 400L/hour
- Clearance height: 450mm



## Flight Type Dishwashers

- Capacity: 3400~13000 dishes/hour
- Voltage: 380V/50Hz/3N
- Water consumption: 420L/hour
- Clearance height: 470mm
- Conveyor speed: 1.6/2.2/3m/min



---

# Undercounter Glasswasher

---

## Recommended Application

- Small restaurants, cafes and bars

## High Performance

- 120-second cycle time
- High capacity of 30 racks per hour
- Efficient system equipped with rotating arms, powerful wash pump and large wash tank for high washing performance
- Thermal control precision ensures that rinse water temperature is always optimized for perfect hygiene
- Highly effective filtering system prevents dirt or food particles from getting trapped and easy to clean
- Double-skin door ensures low noise level and less heat emission

## Simple To Use

- Ergonomically designed handle for safety and counter-balance door is easy to open and close
- User-friendly electro-mechanical control panel
- Wide range of optional accessories for different types of cups and cutlery
- Detergent and rinse aid dispensers are included for convenience
- Components are accessible from the front for easy service and maintenance
- All internal components (wash arms, rinse arm) can be easily removed for cleaning

## Reliability and Safety

- Washing can be stopped when door is open to avoid risks of injuries
- Manufactured in Italy and CE compliant
- Safety design to prevent dry heating failure at low water level



Undercounter Glasswasher



User-friendly control panel



Easily removed for cleaning



Efficient washing system



Counter-balance door

## Main Technical Data

Model	VSG
Name	Undercounter Glasswasher
Max capacity(rack/hour)	30
Booster heater(kW)	2.7
Tank heater(kW)	2.4
Wash pump(kW)	0.2
Booster water (kW)	/
Basket dimension(mm)	400*400
Clearance height(mm)	290
Wash temperature(°C)	60
Rinse temperature(°C)	82
Booster water consumption(l/rack)	2
Net weight(Kg)	38
External dimension(W×D×H mm)	455*550*700

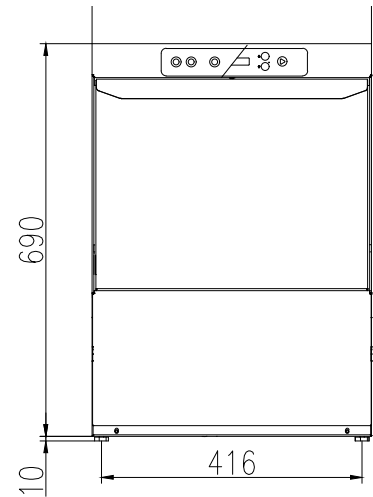

## Installation Requirements

Power Requirements	220V/50Hz/1N
Rated current of circuit breaker(A)	20
Total amps required(A)	13
Total connected load(kW)	2.9
Incoming water pressure(bar)	2-5
Incoming water hardness(ppm)	34-103
Incoming water temperature(°C)	10-65
Diameter of water inlet hose	G3/4"
Diameter of drain pipe	29mm (OD)

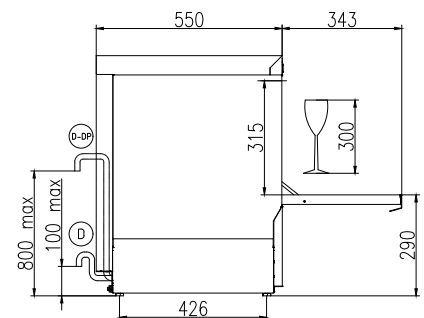
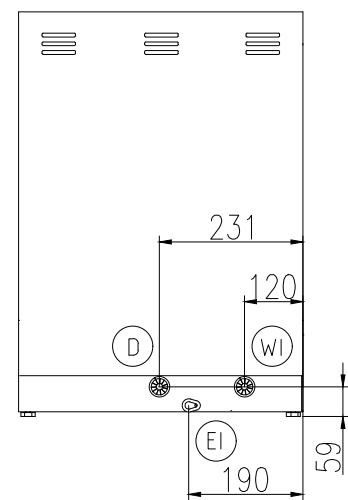

## Accessories

Detergent dispenser	• included
Rinse aid dispenser	• included

WI=Water Inlet  
 D=Drain Outlet  
 EI=Cable Connection  
 EQ=Equipotential Screw  
 XD=Detergent installation inlet  
 XR=Rinse aid installation inlet

## Recommendation

- Electrical connection: 220V/50Hz/1N + Ground with a separate external circuit breaker
- The machine can be directly connected to the water supply system. The lowest incoming water pressure should be 2 bar

---

# Undercounter Dishwasher

---

## Recommended Application

- Restaurants, cafes, bars and small canteens. Recommended capacity up to 300 covers per day

## High Performance

- 90/120/180-second cycle options for different soiled items
- High capacity of up to 40 racks/hour
- Improved hygiene with triple-filtering system; large tank with double layer strainer keeps water clean and reduces changing time
- Thermal control precision ensures that rinse water temperature is always optimized for perfect hygiene
- Double-skin door ensures low noise level and less heat emission

## Simple To Use

- User-friendly electronic control panel displays temperature and working status
- Drain pump included to optimize internal space, and up to 50cm in height
- All internal components (wash and rinse arms) can be easily removed for cleaning, and can be assembled without the use of tools to facilitate daily cleaning
- Deep drawn pressed tank with rounded corners for ease of cleaning
- Components are accessible from the front for easy service and maintenance



Undercounter Dishwasher

## Reliability and Safety

- Washing can be stopped when door is open to avoid risks of injuries
- Heater designed with advanced process for high reliability
- IPX4 water protection
- CB certified for Safety and GB 14934 certified for Hygiene
- Safety design to prevent dry heating failure at low water level



Easy frontal access for key components



Heater designed with advanced process for high reliability



Easily removed for cleaning

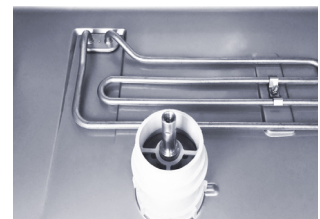

Deep drawn tank built for reliability and hygiene

## Main Technical Data

Model	UD-1
Name	Undercounter Dishwasher
Max capacity(rack/hour)	40
Booster heater(kW)	3/4.5
Tank heater(kW)	2
Wash pump(kW)	0.55
Booster water (kW)	/
Basket dimension(mm)	500*500
Clearance height(mm)	310
Wash temperature(°C)	55-65
Rinse temperature(°C)	80-90
Booster water consumption(l/rack)	2.8
Net weight(Kg)	55
External dimension(W×D×H mm)	600*600*840

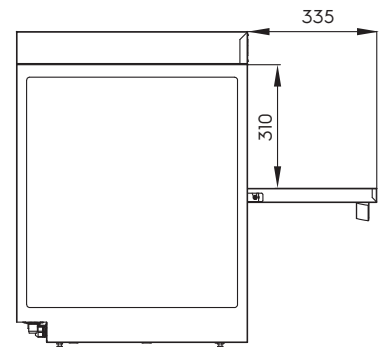
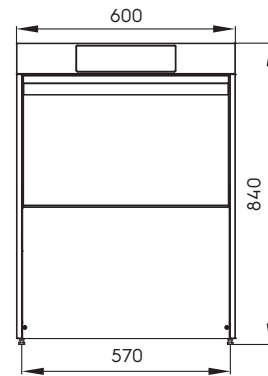

## Installation Requirements

Power Requirements	220V/50Hz/1N	380V/50Hz/3N
Rated current of circuit breaker(A)	25	16
Total amps required(A)	17	9
Total connected load(kW)	3.55	5.05
Incoming water pressure(bar)	2-5	2-5
Incoming water hardness(ppm)	34-103	34-103
Incoming water temperature(°C)	40-60	10-60
Diameter of water inlet hose	G3/4"	G3/4"
Diameter of drain pipe	22mm (OD)	22mm (OD)

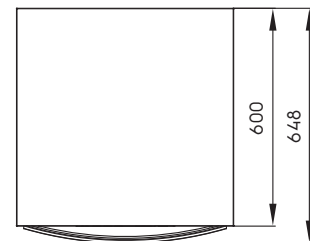

## Accessories

Detergent dispenser	○ optional
Rinse aid dispenser	● included

## Recommendation

- Electrical connection: 220V/1N + Neutral + Ground or 380V/3N + Neutral + Ground with a separate external circuit breaker
- The machine can be directly connected to the water supply system.  
The lowest incoming water pressure should be 2 bar

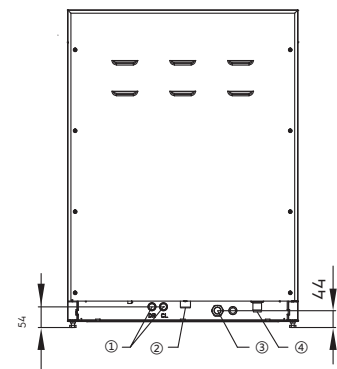

- ① Dispenser Connection
- ② Water Inlet Connection
- ③ Drain Outlet Connection
- ④ Cable Connection

---

# Hood Type Dishwasher-VHT 60

---

## Recommended Application

- Hotels, restaurants and canteens. Recommended capacity up to 300 covers per day

## High Performance

- Up to 60 racks per hour, can be connected to cold and hot water supply
- 60/90/120-second cycle options for different soiled items
- An effective rinse system uses only 2.5 liters of clean hot water per cycle for lower running costs and energy consumption
- Built-in pressure boiler designed to raise incoming water to a guaranteed minimum temperature of 82°C for sanitizing rinse
- Slanted wash arms and ceiling for maximum performance as wash water no longer drops on dishes after rinsing phase
- Optimal washing results regardless of where the items are placed, as a result of the unique shape of the spray nozzles and the upper and lower rotating arms

## Simple To Use

- Internal components (wash arms, rinse arms, tank filter and rack support) can be easily removed for daily cleaning
- Tank filter can be accessed from the front for easy cleaning
- Main components are accessible from the front for easy service and maintenance
- User-friendly electronic controls with built-in programming, self-diagnostics for easy serviceability

## Reliability & Safety

- Washing can be stopped when door is open to avoid risks of injuries
- CB certified for Safety and GB 14934 certified for Hygiene
- IPX4 water protection
- Safety design to prevent dry heating failure at low water level



Hood Type Dishwasher



Easy frontal access for key components



Water tank with rounded edges for ease of cleaning and hygiene

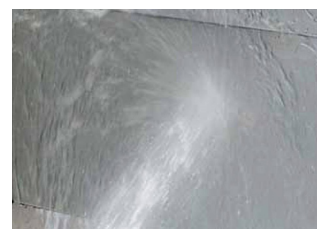

IPX4 water protection



## Main Technical Data

Model	VHT 60
Name	Hood Type Dishwasher
Max capacity(rack/hour)	60
Booster heater(kW)	12
Tank heater(kW)	3
Wash pump(kW)	0.8
Basket dimension(mm)	500*500
Clearance height(mm)	440
Wash temperature(°C)	55-65
Rinse temperature(°C)	82-90
Booster water consumption(l/rack)	2.5
Net weight(Kg)	105
External dimension(W×D×Hmm)	746*755*1512

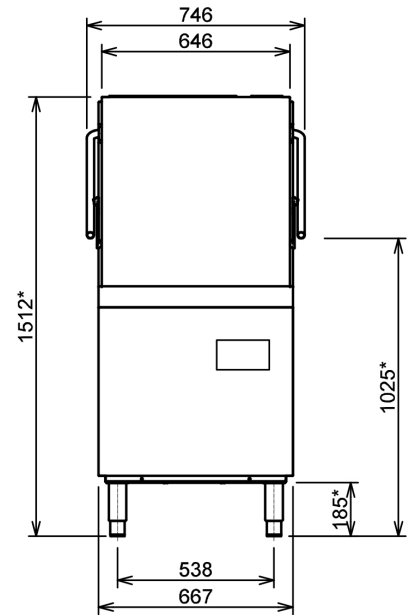

## Installation Requirements

Power Requirements	380V/50Hz/3N
Rated current of circuit breaker(A)	40
Total amps required(A)	24
Cross section of cable(mm <sup>2</sup> )	6
Total connected load(kW)	15.8
Incoming water pressure(bar)	2-3
Incoming water hardness(ppm)	34-103
Incoming water temperature(°C)	10-60
Diameter of water inlet hose	G3/4"
Diameter of drain pipe	40mm(OD)

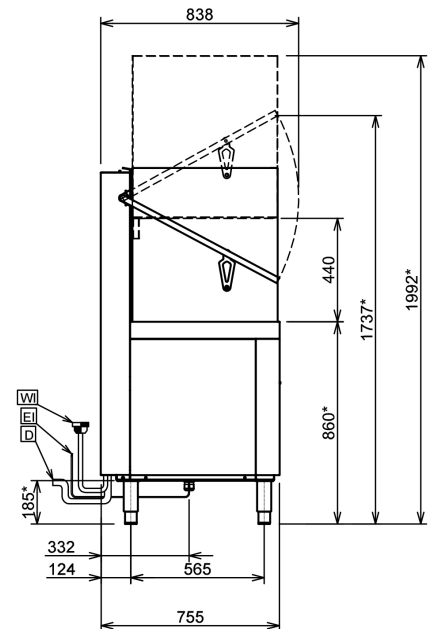

WI=Water Inlet      EQ=Equipotential Screw  
D=Drain Outlet      XD=Detergent installation inlet  
EI=Cable Connection      XR=Rinse aid installation inlet

## Accessories

Detergent dispenser	○ optional
Rinse aid dispenser	○ optional

## Recommendation

- Electrical connection: 380V/3N + Neutral + Ground with a separate external circuit breaker
- In the washing process, additional exhaust hood, working tables, baskets, chemical dispensers, detergent and rinse aid need to be equipped
- The machine can be directly connected to the water supply system. The lowest incoming water pressure should be 2-3 bar
- If a hood or vent is needed, the minimum capacity should be 2.8 m<sup>3</sup>/min

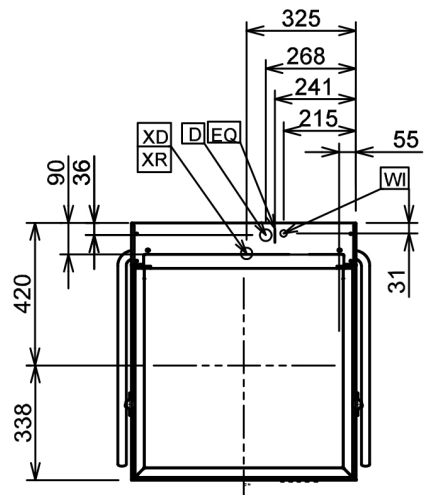

---

# Hood Type Dishwasher-VHT 65

---

## Recommended Application

- Hotels, restaurants and canteens. Recommended capacity up to 300 covers per day

## High Performance

- Up to 65 racks per hour, can be connected to cold and hot water supply
- 55/84/150-second cycle options for different soiled items
- Built-in atmospheric boiler guarantees high quality rinsing is always achieved regardless of the inlet water conditions. Ensures constant high temperature of 84 °C and strong pressure of water during the rinse phase
- Unique temperature interlock guarantees required temperatures in both the wash and final rinse
- An effective rinse system using only 2.3 liters of clean hot water per cycle for lower running costs and energy consumption
- Slanted wash arms for maximum performance as wash water no longer drops on dishes after rinsing phase

## Simple To Use

- Internal components (wash arms, rinse arms, tank filter and rack support) can be easily removed for daily cleaning
- Tank filter can be accessed from the front for easy cleaning
- Main components are accessible from the front for easy service and maintenance
- State-of-the-art electronic controls with built-in programming, self-diagnostics and automatic interior self-cleaning cycle
- Convertible from 3 phase to 1 phase onsite

## Reliability and Safety

- Washing can be stopped when door is open to avoid risks of injuries
- CB certified for Safety and GB 14934 certified for Hygiene
- IP25 - Full protection against water jets and solid objects/animals (larger than 6mm)
- Safety design to prevent dry heating failure at low water level



Hood Type Dishwasher

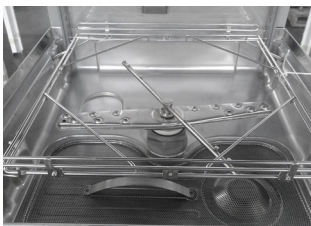

Durable stainless steel arms



Water tank with rounded edges for ease of cleaning and hygiene



IP25 water protection

## Main Technical Data

Mode	VHT 65
Name	Hood Type Dishwasher
Max capacity(rack/hour)	65
Booster heater(kW)	9
Tank heater(kW)	3
Wash pump(kW)	0.8
Booster water (kW)	0.3
Basket dimension(mm)	500*500
Clearance height(mm)	440
Wash temperature(°C)	55-65
Rinse temperature(°C)	82-90
Booster water consumption(l/rack)	2.3
Net weight(Kg)	123
External dimension(W×D×H mm)	746*755*1549

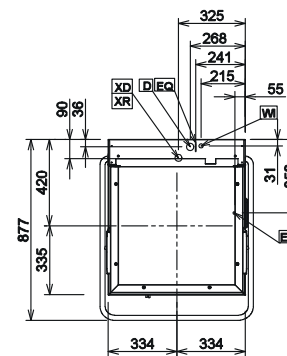
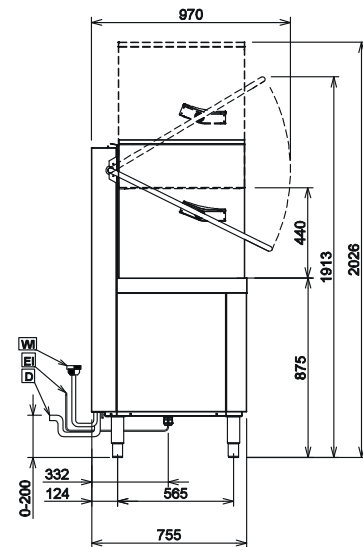
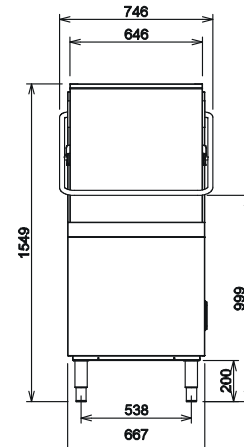

## Installation Requirements

Power Requirements	380V/50Hz/3N
Rated current of circuit breaker(A)	32
Total amps required(A)	20
Cross section of cable(mm <sup>2</sup> )	4
Total connected load(kW)	12.9
Incoming water pressure(bar)	0.5-7
Incoming water hardness(ppm)	34-103
Incoming water temperature(°C)	10-65
Diameter of water inlet hose	G3/4"
Diameter of drain pipe	40mm (OD)

## Accessories

Detergent dispense	○ optional
Rinse aid dispenser	○ optional

## Recommendation

- Electrical connection: 380V/3N + Neutral +Ground with a separate external circuit breaker
- In the washing process, additional exhaust hood, working tables, baskets, chemical dispensers, detergent and rinse aid need to be equipped
- The machine can be directly connected to the water supply system. The lowest incoming water pressure should be 0.5bar
- If a hood or vent is needed, the minimum capacity should be 2.8 m<sup>3</sup>/min

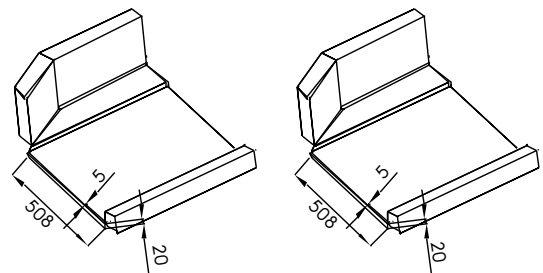

W1=Water inlet  
 D=Drain Outlet  
 El=cable connection  
 EQ=Equipotential Screw  
 XD=Detergent installation inlet  
 XR=Rinse aid installation inlet

---

# One Tank Rack Type Dishwasher

---

## Recommended Application

- R-IE - Hotels, restaurants and canteens. Recommended capacity up to 200 seating for hotels or 800 covers for staff canteens per day
- R-IER - Hotels, restaurants and canteens. Recommended capacity up to 300 seating for hotels or 900 covers for staff canteens per day

## High Performance

- Up to 200 racks per hour for single rinse and 220 racks per hour for duo rinse. Duo rinse system not only guarantees hygiene but also save running costs by up to 15%
- Auto On/Off switches reduce water and energy consumption when no rack is loaded
- Thermal control precision ensures that rinse water temperature is always optimized for perfect hygiene
- Built-in pressure reducer ensures stable rinse water pressure during the rinse phase
- Advanced filtering system keeps the wash water free of food residue thus improving the efficiency of the detergent for an optimal washing result



One-tank single rinse

## Simple To Use

- User-friendly operation panel with temperature display
- Internal components (wash arms, rinse arms, tank filter, rack support) can be easily removed for cleaning
- Electrical control box and main components on top and front for easy service and maintenance
- Preset external chemical connection for quick on-site installation



One-tank duo rinse

## Reliability and Safety

- Washing can be stopped when door is open to avoid risks of injuries
- CB compliant for Safety and GB 14934 certified for Hygiene
- Safety design to prevent dry heating failure at low water level



High load capacity



SS construction and internal components for high durability



User-friendly operation panel with temperature display



Auto On/Off switches

## Main Technical Data

Model	R-1E	R-1S	R-1ER	R-1SR
Name	One-tank single rinse		One-tank duo rinse	
Max capacity (rack/hour)	200	200	220	220
Booster heater (kW)	3600	3600	3960	3960
Basket dimension(mm)	500*500	500*500	500*500	500*500
Washing height	450	450	450	450
Wash temperature(°C)	55-65	55-65	55-65	55-65
Rinse temperature(°C)	80-90	80-90	80-90	80-90
Booster water consumption(l/rack)	2	2	1.8	1.8
Net weight(Kg)	224	224	302	302

## Installation Requirements

Power Requirements	380V/50Hz/3N	380V/50Hz/3N	380V/50Hz/3N	380V/50Hz/3N
External dimension(w×d×h mm)	1148*706*1840	1148*706*1840	1748*706*1713	1748*706*1713
Total connected load((kW)	46	2.5	46	3
Booster heater(kW)	36	/	36	/
Tank heater(kW)	7.5	/	7.5	/
Wash pump(kW)	1.5	1.5	1.5	1.5
Rinse pump(kW)	/	/	0.25	0.25
Drive motor(kW)	0.2	0.2	0.2	0.2
Incoming water pressure(bar)	2-5	2-5	2-5	2.5
Incoming water hardness(ppm)	34-103	34-103	34-103	34-103
Incoming water temperature (°C)	10-60	10-60	10-60	10-60
Diameter of water inlet hose(inch)	G3/4"	G3/4"	G3/4"	G3/4"
Diameter of drain pipe	G2" OR DN50	G2" OR DN50	G2" OR DN50	G2" OR DN50
Total Steam Consumption(Kg/h)	/	75	/	75
Rated current of circuit breaker(A)	100	16	100	16
Total amps required(A)	70	4	70	5
Cross section of cable(mm)	25	2.5	25	2.5
Steam emission(m <sup>3</sup> /h)	> 1000	> 1000	> 1000	> 1000

## Drying Tunnel(option)

size(mm)	900*713*2160	900*713*2160	900*713*2160	900*713*2160
Drying heater(kW)	9.55	0.55	9.55	0.55
Net weight((Kg)	150	150	150	150
Total steam consumption(Kg/hour)	/	15	/	15

## Recommendation

- Electrical connection: 380V/3N + Neutral + Ground with an external circuit breaker
- In the washing process, additional exhaust hood, working tables, baskets, chemical dispensers, detergent and rinse aid need to be equipped
- Machine can be directly connected to the water supply system. The lowest incoming water pressure should be 2 bar
- If a hood or vent is needed, the inlet capacity should be 5.7m<sup>3</sup>/min and the outlet 11.3 m<sup>3</sup>/min

R-1E/R-1S

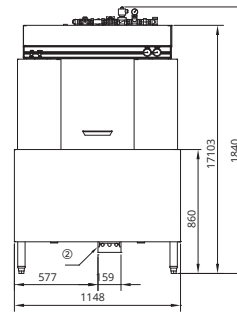

R-1ER/R-1SR

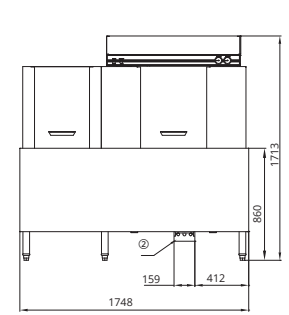

② Drain out

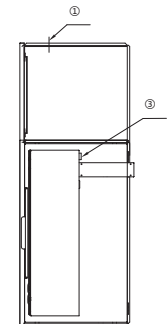
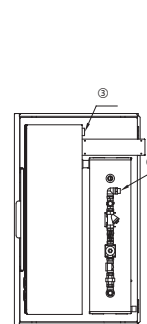
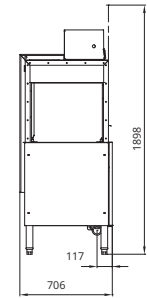
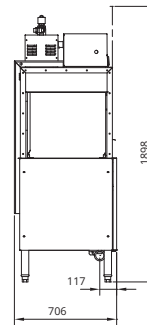

① Water Inlet  
② Cable Connection

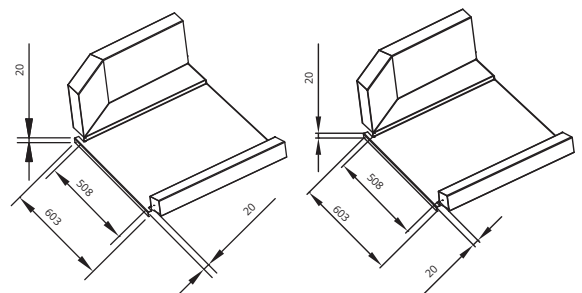

---

# Two Tank Rack Type Dishwashers

---

## Recommended Application

- R-2E - Hotels, restaurants and canteens. Recommended capacity up to 400 seating for hotels or 1000 covers for staff canteens per day
- R-2ER - Hotels, restaurants and canteens. Recommended capacity up to 500 seating for hotels or 1200 covers for staff canteens per day

## High Performance

- Up to 250 racks per hour for single rinse and 280 racks per hour for duo rinse. Duo rinse system not only guarantees hygiene and also reduces running costs by up to 40%
- Auto On/Off switches reduce water and energy consumption when no rack is loaded
- Thermal control precision ensures that rinse water temperature is always optimized for perfect hygiene
- Built-in pressure reducer ensures stable rinse water pressure during the rinse phase
- Highly effective filtering system keeps the wash water free of food residue



Two-tank single rinse

## Simple To Use

- User-friendly operation panel with temperature display
- Internal components (wash arms, rinse arms, tank filter, rack support) can be removed easily for cleaning
- Electrical control box and main components on top and front for easy service and maintenance
- Preset external chemical connection for quick on-site installation



Two-tank duo rinse

## Reliability & Safety

- Washing can be stopped when door is open to avoid risks of injuries
- CB compliant for Safety and GB 14934 certified for Hygiene
- Safety design to prevent dry heating failure at low water level



High load capacity



SS construction and internal components for high durability

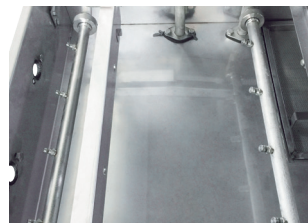

Duo rinse guarantees rinse performance at low water consumption



Auto On/Off switches

## Main Technical Data

Model	R-2E	R-2S	R-2ER	R-2SR
Name	Two-tank single rinse		Two-tank duo rinse	
Max capacity(rack/hour)	250	250	280	280
Booster heater(kW)	4500	4500	5040	5040
Basket dimension(mm)	500*500	500*500	500*500	500*500
Loading height	450	450	450	450
Wash temperature(°C)	55-65	55-65	55-65	55-65
Rinse temperature(°C)	80-90	80-90	80-90	80-90
Booster water consumption (l/rack)	1.6	1.6	1.4	1.4
Net weight(Kg)	304	304	382	382

## Installation Requirements

Power Requirements	380V/50Hz/3N	380V/50Hz/3N	380V/50Hz/3N	380V/50Hz/3N
External dimension(w×d×hmm)	1653*706*1840	1653*706*1840	2253*706*1713	2253*706*1713
Total connected load(kW)	55	4	55	4.5
Booster heater(kW)	36	/	36	/
Tank heater(kW)	7.5*2	/	7.5*2	/
Wash pump(kW)	1.5*2	1.5*2	1.5*2	1.5*2
Rinse pump(kW)	/	/	0.25	0.25
Drive motor(kW)	0.2	0.2	0.2	0.2
Incoming water pressure(bar)	2-5	2-5	2-5	2-5
Incoming water hardness(ppm)	34-103	34-103	34-103	34-103
Incoming water temperature (°C)	10-60	10-60	10-60	10-60
Diameter of water inlet hose(inch)	G3/4"	G3/4"	G3/4"	G3/4"
Diameter of drain pipe(inch)	2" OR DN50	2" OR DN50	2" OR DN50	2" OR DN50
Total Steam Consumption(Kg/h)	/	88	/	88
Rated current of circuit breaker(A)	100	16	100	16
Total amps required(A)	84	7	84	7
Cross section of cable(mm)	25	2.5	25	2.5
Steam emission(m³/h)	> 1000	> 1000	> 1000	> 1000

## Tunnel (option)

size(mm)	900*713*2160	900*713*2160	900*713*2160	900*713*2160
Drying heater(kW)	9.55	0.55	9.55	0.55
Net weight((Kg)	150	150	150	150
Total steam consumption(Kg/hour)	/	15	/	15

## Recommendation

- Electrical connection: 380V/3N + Neutral + Ground with an external circuit breaker
- In the washing process, additional exhaust hood, working tables, baskets, chemical dispensers, detergent and rinse aid need to be equipped
- Machine can be directly connected to the water supply system. The lowest incoming water pressure should be 2 bar
- If a hood or vent is needed, the inlet capacity should be 5.7m³/min and the outlet 11.3 m³/min

R-2E/R-2S

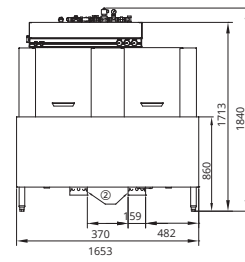

R-2ER/R-2SR

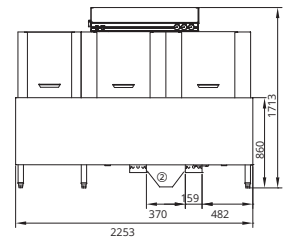

② drain out

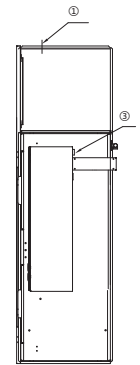
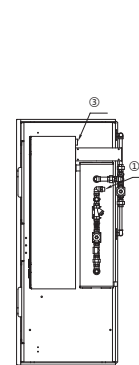
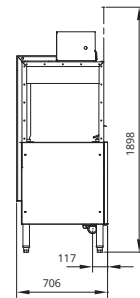
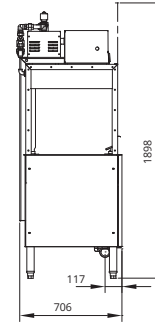

① water inlet  
② cable connection

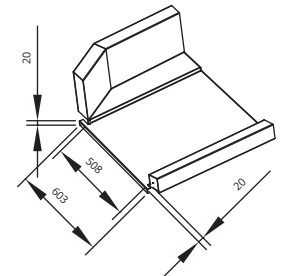
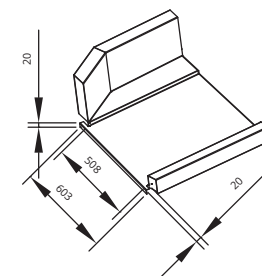

---

# Flight Type Dishwasher FEA-series

---

## Recommended Application

- Hotels, banquets, restaurants, staff canteens and institutions. Recommended capacity up to 600 seating for banquets or 3600 covers for staff canteens per day

## High Performance

- Power wash and rinse systems ensure optimal cleaning results and reduce energy consumption by up to 20%
- Flexible modular design to meet various washing needs, from 3400 to 13000 dishes per hour
- Thermal control precision ensures that rinse water temperature is always optimized for perfect hygiene
- Highly efficient dryer and air blower to ensure good drying results in shorter time

## Simple To Use

- Easy to operate with Electromechanical button
- Electrical control box and main components on top and front for easy service and maintenance
- Thoughtfully designed height level for operator to reach items easily
- Multi-purpose conveyor with overload protection to fit different types of wares
- Emergency stop devices are conveniently located at the loading and unloading sections to ensure safety for the operator

## Reliability & Safety

- Washing can be stopped when door is open to avoid risks of injuries
- Safety switch at loading section to stop the machine in case wares are not removed from conveyor to avoid damages to the wares
- CQC tested for Safety and GB 14934 certified for Ware Sanitation
- Safety design to prevent dry heating failure at low water level
- Optional ESD(Energy Saving Device) available (savings 9kWh)



Flight Type Dishwasher FEA-series

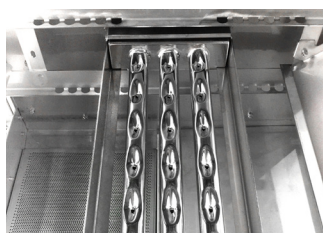

Power wash and rinse systems ensure optimal cleaning results



Overload ware protection

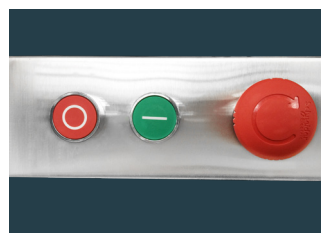

Emergency buttons conveniently located



Easy to clean with side strainer



## Model configuration

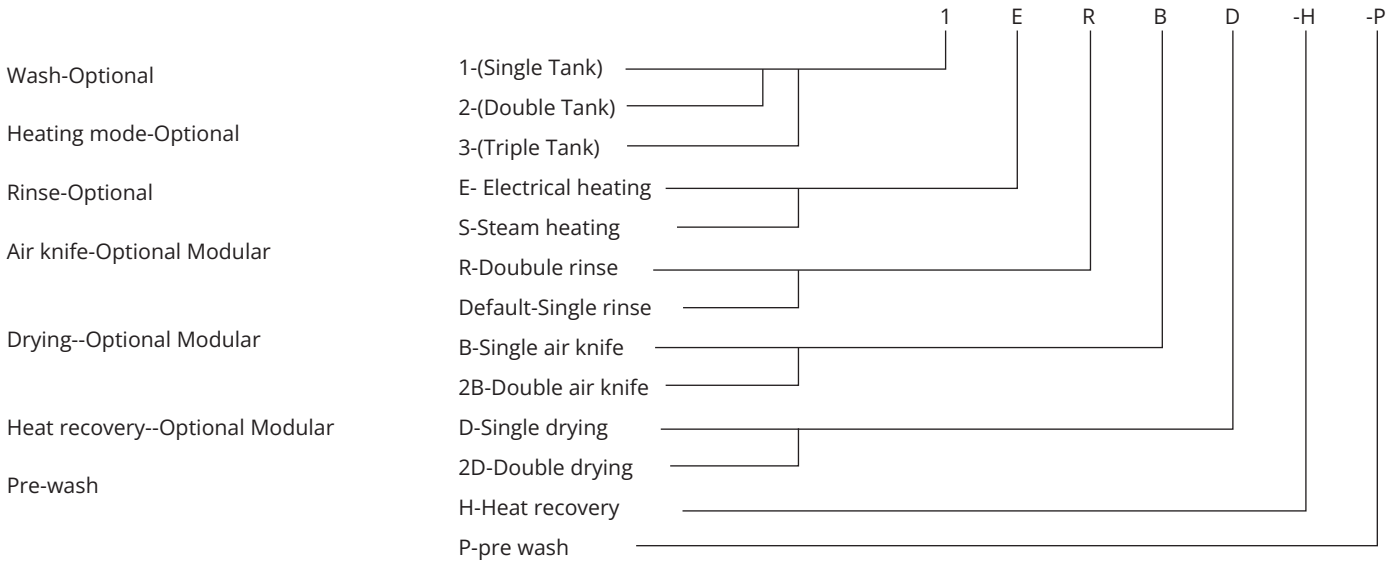

## Main Technical Data

Model	Heating	External dimension (w×d×h mm)	Max capacity (dish/hour)	Total connected load(KW)	Max water consumption (liter/hour)	Tank Heater (kW)	Booster Heater (kW)	Power of drying tunnel (kW)	Pump+ Conveyor motor (kW)	Total steam consumption (Kg)	Cross section of cable (mm <sup>2</sup> )	Rated current of circuit breaker (A)
FEA-1ER/FEA-1SR	Electricity/steam	3255×980×1720	3400 ~ 6800	54/3	420	15	36	--	2.8	90	25	100/20
FEA-1ERD/FEA-1SRD	Electricity/steam	4155×980×2040	3400 ~ 6800	67/4	420	15	36	13	2.8	110	35	125/20
FEA-2ER/FEA-2SR	Electricity/steam	4810×980×1720	4800 ~ 9600	71/5	420	15×2	36	--	5	116	35	125/25
FEA-2ER-P/FEA-2SR-P	Electricity/steam	4810×980×1720	4800 ~ 9600	56/5	420	15	36	--	5	90	25	100/25
FEA-2ERD/FEA-2SRD	Electricity/steam	5710×980×2040	4800 ~ 9600	84/6	420	15×2	36	13	5	137	50	150/25
FEA-2ERD-P/FEA-2SRD-P	Electricity/steam	5710×980×2040	4800 ~ 9600	69/6	420	15	36	13	5	110	35	125/25
FEA-3ER/FEA-3SR	Electricity/steam	6215×980×1720	6500 ~ 13000	89/7.2	420	15×3	36	--	7.2	142	50	200/40
FEA-3ER-P/FEA-3SR-P	Electricity/steam	6215×980×1720	6500 ~ 13000	74/7.2	420	15×2	36	--	7.2	116	35	150/40
FEA-3ERD/FEA-3SRD	Electricity/steam	7115×980×2040	6500 ~ 13000	102/8	420	15×3	36	13	7.2	163	50	200/40
FEA-3ERD-P/FEA-3SRD-P	Electricity/steam	7115×980×2040	6500 ~ 13000	87/8	420	15×2	36	13	7.2	137	50	200/40

## Installation Requirements

Power Requirements	380V/50Hz/3N
Diameter of water inlet pipe(inch)	G3/4"
Diameter of drain pipe(inch)	2" OR DN50
Incoming water pressure(bar)	2 - 5
Incoming water temperature(C)	10 - 60
incoming water hardness(g/l)	0.034 - 0.103

- Power requirements: 380V/50Hz/3N + Neutral + Ground, with an external circuit breaker

- The machine can be directly connected to the water supply system. The lowest incoming water pressure should be 2 bar

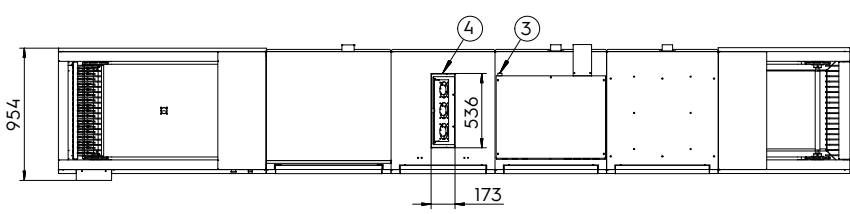
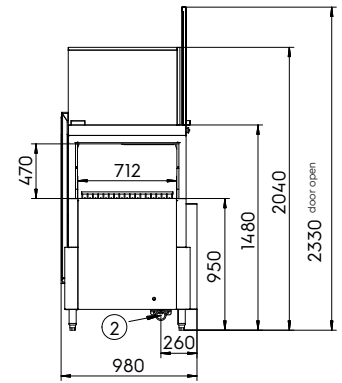
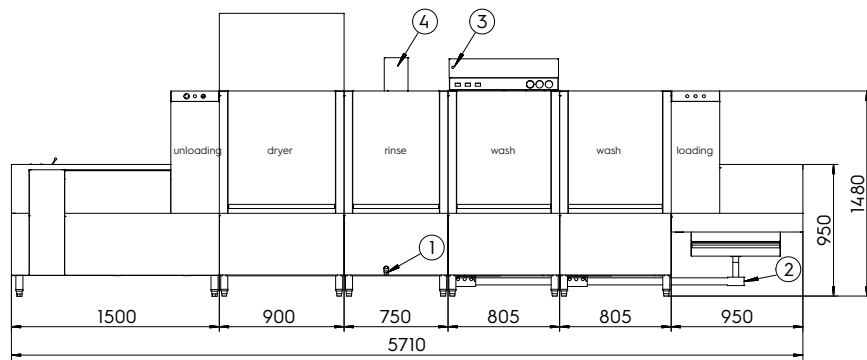
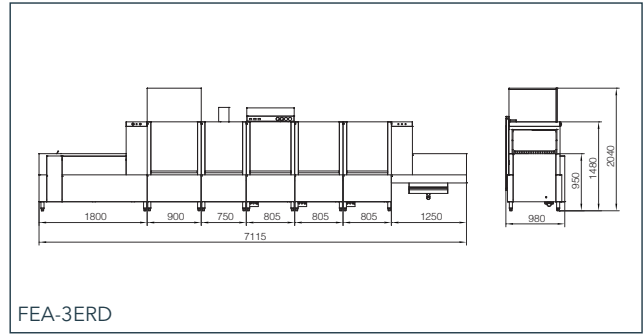
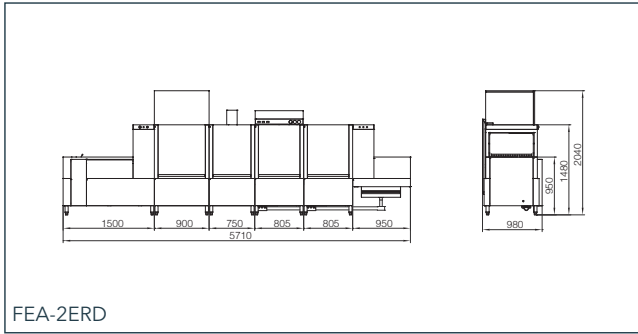
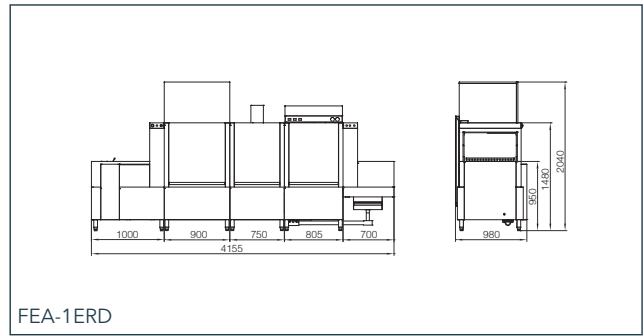
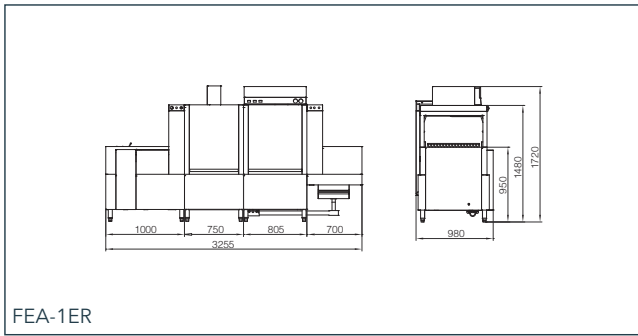

- FEA-2ERD
- ① Water inlet
  - ② Drain out
  - ③ Cable connection
  - ④ Vent





“Quality & Value” is what Veetsan stands for and has proven in the market. Being part of Electrolux Professional Group, a global leader in commercial appliances, Veetsan – the dishwashing professional supports businesses to becoming more profitable, reliable and trustworthy. The Veetsan factory is ISO 9000-certified and all products are 100% quality-tested by experts at Intertek and SGS.

Factory address:

No. 2688, Huancheng West Road, Nanqiao  
Town, Fengxian District, Shanghai, China

Discover the complete range online and on WeChat:

[www.Veetsan.asia](http://www.Veetsan.asia)



Part of  Electrolux  
Professional  
Group